

Pre-primary: Week 17 & 18 / Shure ntateko: Shivike 17 na 18

5-6 years/ mwaka 5-6

English / Rumanyo

Draw yourself in your school uniform. /
Kufaneke naghumoye mumudwato washure.

My School / Shure yande



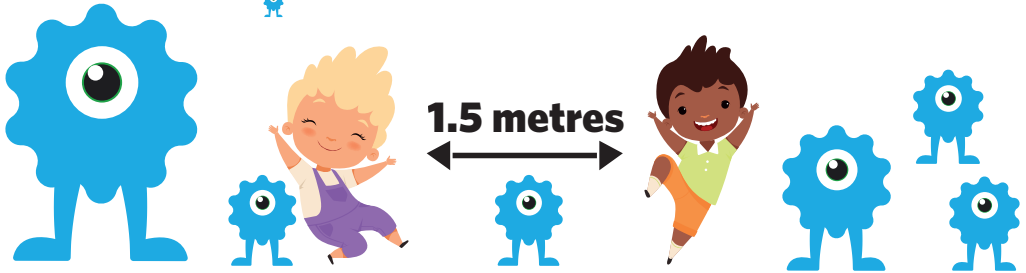

- 1**
- 2**
- 3**
- 4**
- 5**

These numbers indicate which day you can complete each worksheet! But if you want to, you can work ahead and do the rest as well.

This publication is a collaboration between the Ministry of Education, Arts and Culture and Namibia Media Holdings. This publication is sponsored by the Ministry.

Copyright © Ministry of Education, Arts and Culture. All parts of this publication cannot be reproduced, stored in a retrieval system or transmitted in any form or by any means, electronic, mechanical, photocopying, recording or otherwise without prior permission of the Ministry of Education, Arts and Culture or the Publisher.

Production by: Namibia Media Holdings **NAMIBIA MEDIA HOLDINGS**

Printing: Newsprint Namibia



My School / Shure yande

Identify names with same beginning sounds and circle them. /
Dimburura madina ghakutamikita namushagharo wakukufana makura
ghughadingilike.

Titus /
Kahare

Anna

Tim /
KudumoTory /
Katiku

Mark with a cross (x) all the missing objects in the second picture. /
Mereka na (X) vininke navitjje vinapiro palifano lyauviri.



Shivike 17

Shure ntateko



Cut out the pictures and paste them in the correct order. /
Tenga mafano nakugharameka mulikukwamo lyaguhunga.

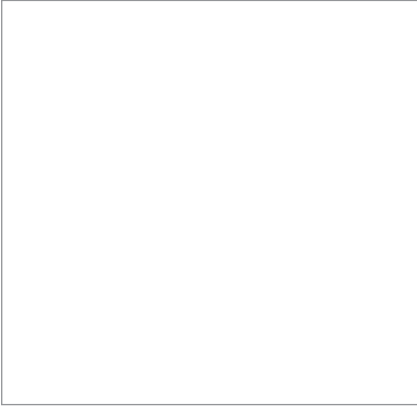

Shivike 17

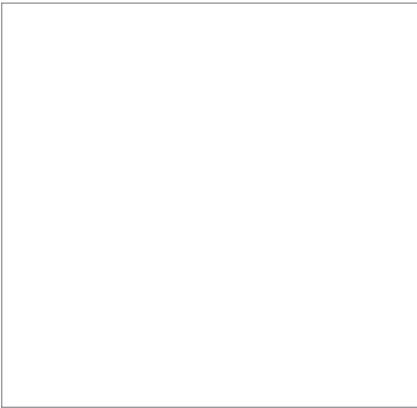

Shure ntateko

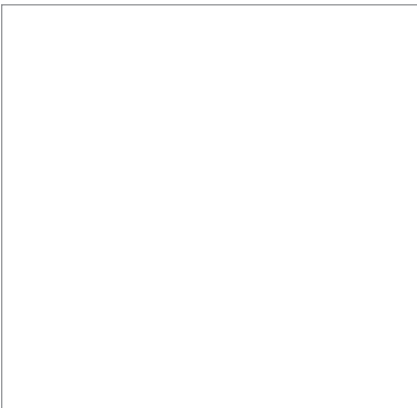



Trace the patterns. / Dekera mapi.

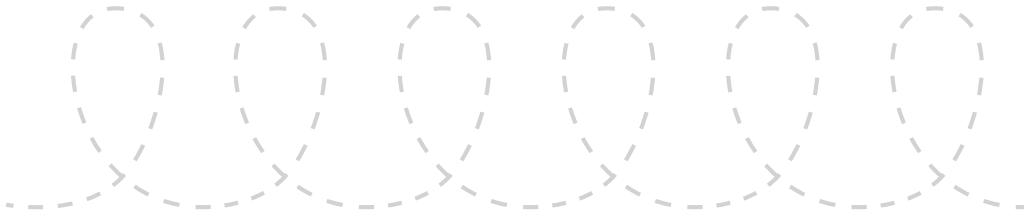

Shivike 17

Shure ntateko

Draw a big circle. Then draw a small square in the circle. /
Faneka lighuta lyalinene makura ghufaneke shikwambando munda
yalighuta.

Shivike 17

Shure ntateko



Circle anything orange in the picture./
Dingilika kehe shino sharuvara rwashinaghuguni palifano.



Shivike 17

Shure ntateko

Complete the number pattern. / Manita mapi ghanomora.

5, 4, 3, 2, 1

5, 4, __, __, __

1, 2, 3, 4, 3

___ / ___ / ___ / ___ / ___

3, 2, 5, 2, 3

___ / ___ / ___ / ___ / ___

Shivike 17

Shure ntateko



Match the objects with the same length using lines. /
Ruwanita mutunda ghushetakanite vininke vyaunaure wakukufana.

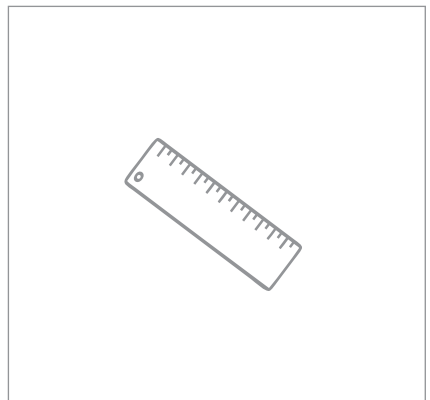
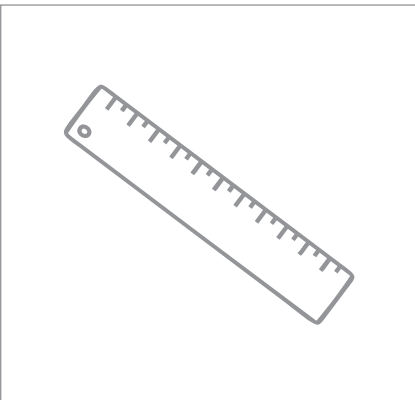
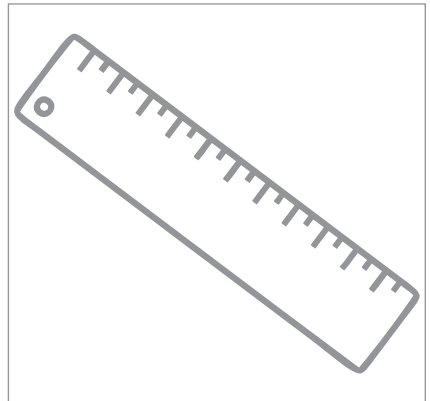
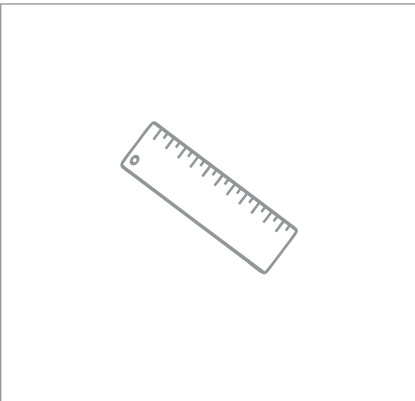
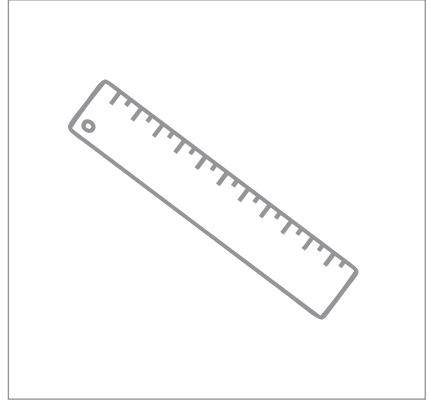
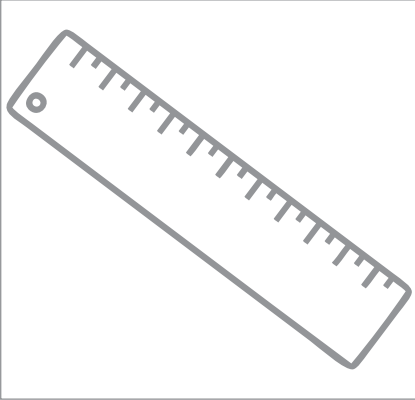

Shivike 17

Shure ntateko

Spot the objects which are near and circle them. /
Kenga po vininke ovyo vina karero papepi makura ghuvidingilike.

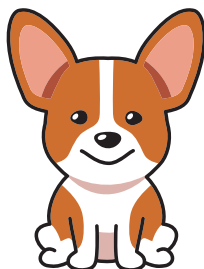
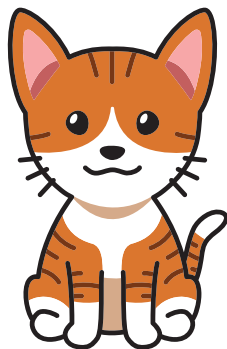

Cut out the glasses and paste them from full to empty. /
 Tenga nkinda damakende nakudirameka mulikukwamo kutamekera
 kuyakuyura dogoro yaghukahe.

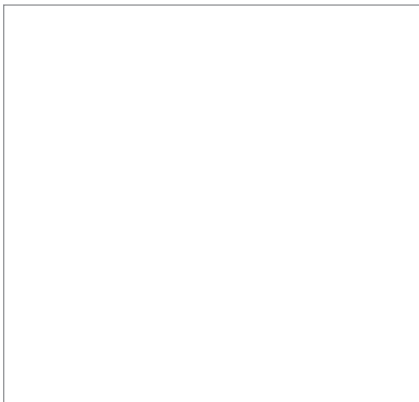
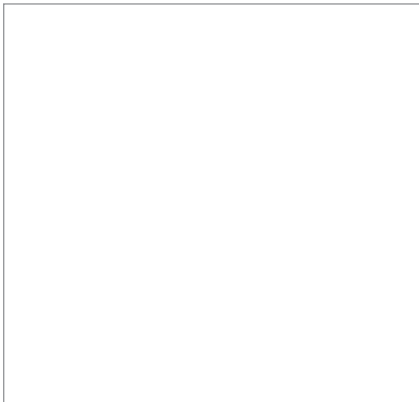
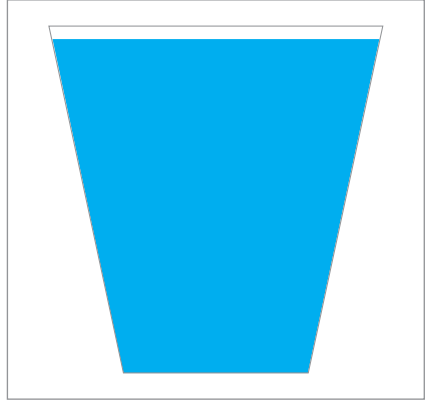

Shivike 17

Shure ntateko



Circle all the number 5's. / Dingilika nomora 5 nadintje.

2 4 1 3 4
 2 3 5 2 1
 5 4 3 1 4
 2 5 3 2
 1 5 3 1 3
 1 1 4 1
 3 4 2 5

Shivike 17

Shure ntateko

Trace the dotted triangle. / Dekera shikovhutatu shavindomo.

Shivike 17

Shure ntateko

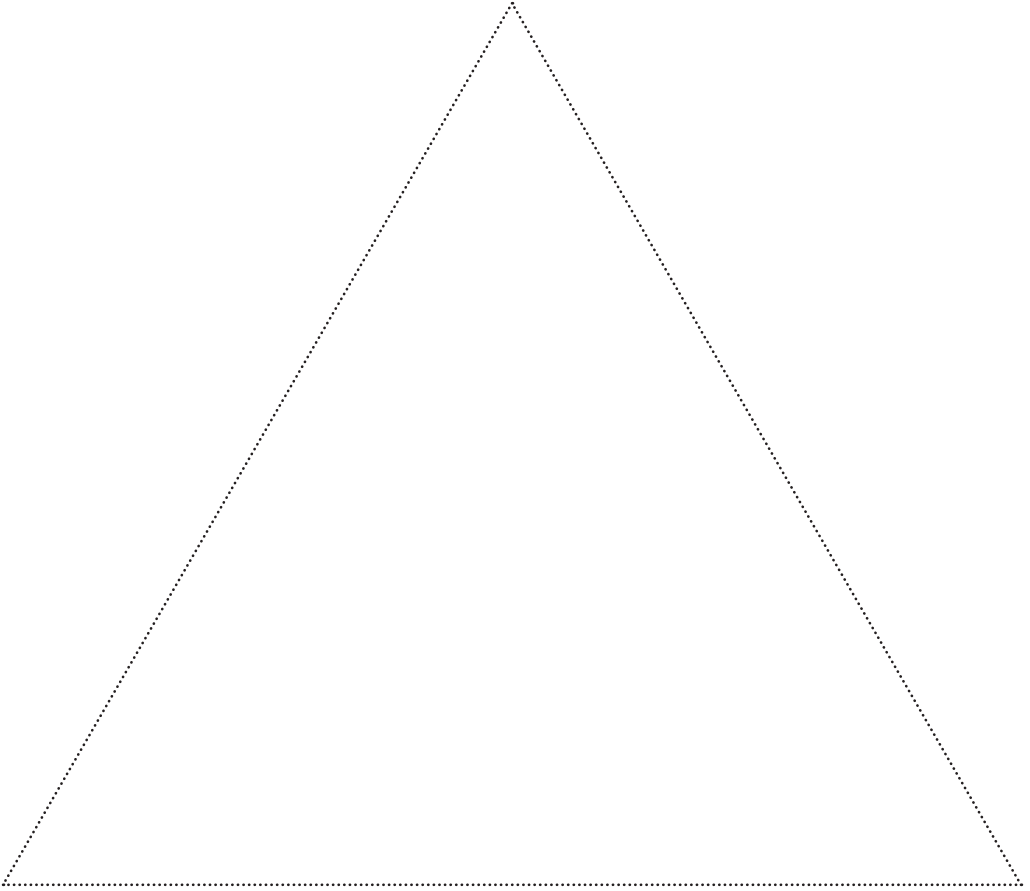

Draw a triangle. / Faneka shikovhutatu mushimbangu.

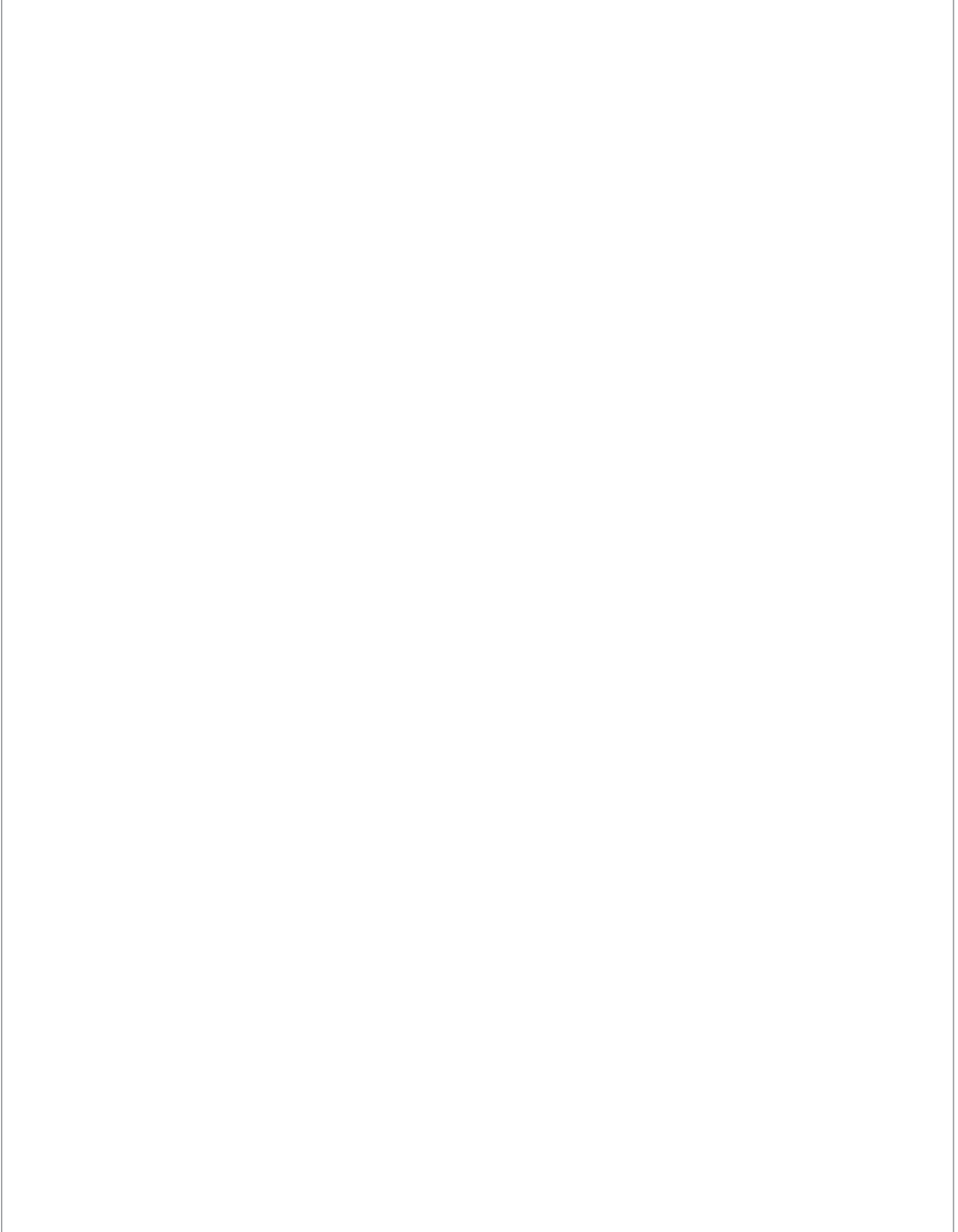

Colour all the triangles with an orange colour, all circles with a blue colour and all squares with yellow colour. / Kwita ndombwe yashinaghuguni vikovhutatu navintje, ndombwe yashinaliwiru nkata nadintje ntani ndombwe yashinalihenga vikwambando navintje.

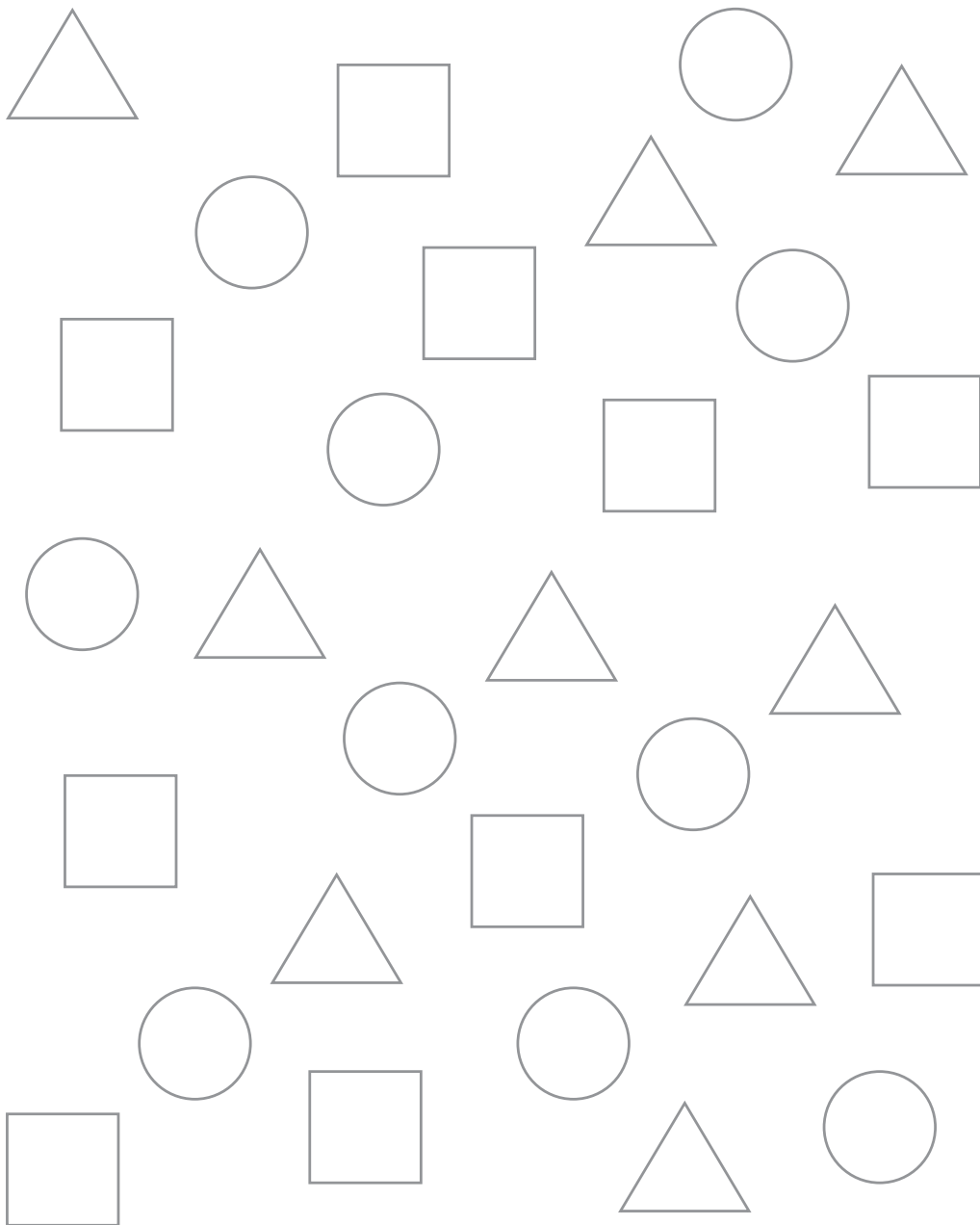

Shivike 18

Shure ntateko



Mime what is shown in the picture. /
Temwinina ovyo vana kuruwana palifano.



Shivike 18

Shure ntateko



Circle all clothes for cold weather. / Dingilika vyuma navintje vyakudwata ntjene mpepo ndi ghutenda.

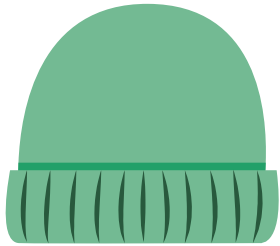

Shivike 18

Shure ntateko

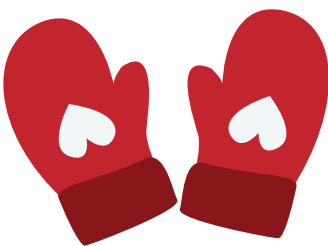
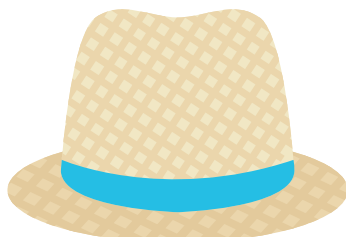
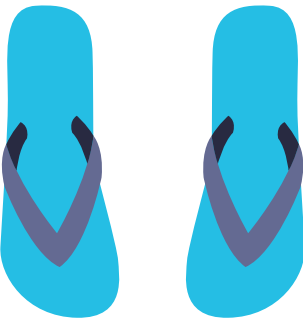

Identify with a cross (X) the correct picture when crossing the road. /
Mereka na (X) lifano lyaguhunga mukuvatuka shitaghura.

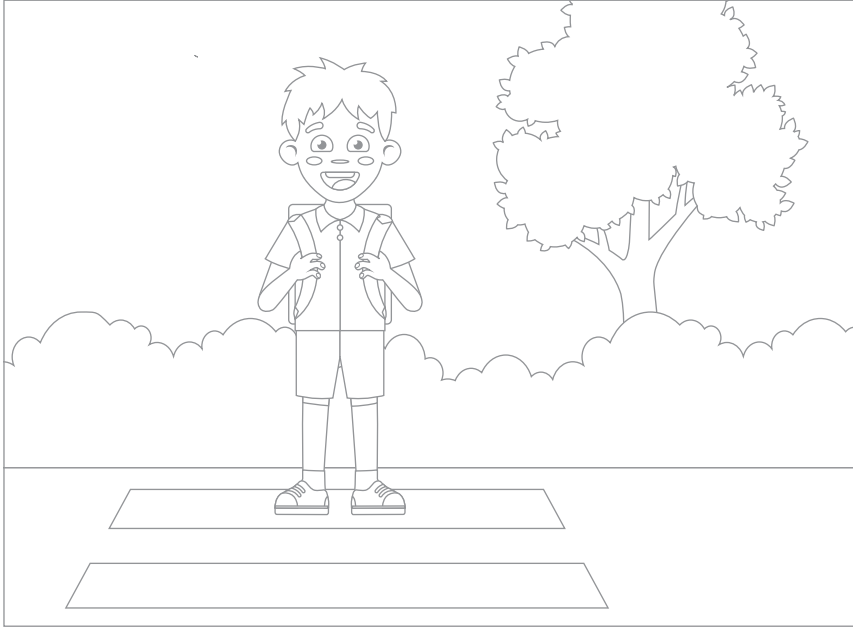

Shivike 18

Shure ntateko

Circle all the 10c. / Dingilika 10c nadintje.



Shivike 18

Shure ntateko



Draw any two classroom objects, talk about them with the teacher or parent./ Faneka kehe vininke viviri vyamunkondarongero. Timwitira kuhamena kuvininke ovyo namitiri ghoye ndi po navakurona voye.

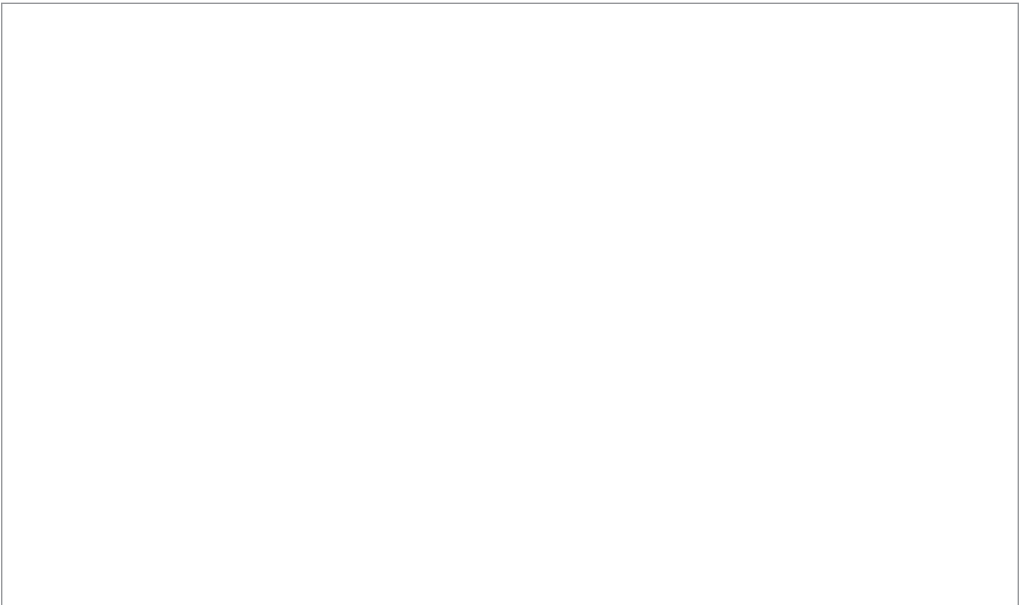

Shivike 18

Shure ntateko

Colour the stop sign with a red crayon./ Kwita ndombwe yayigeha shiyivito shakuyimana nashikwitito shashigeha.

Shivike 18

Shure ntateko

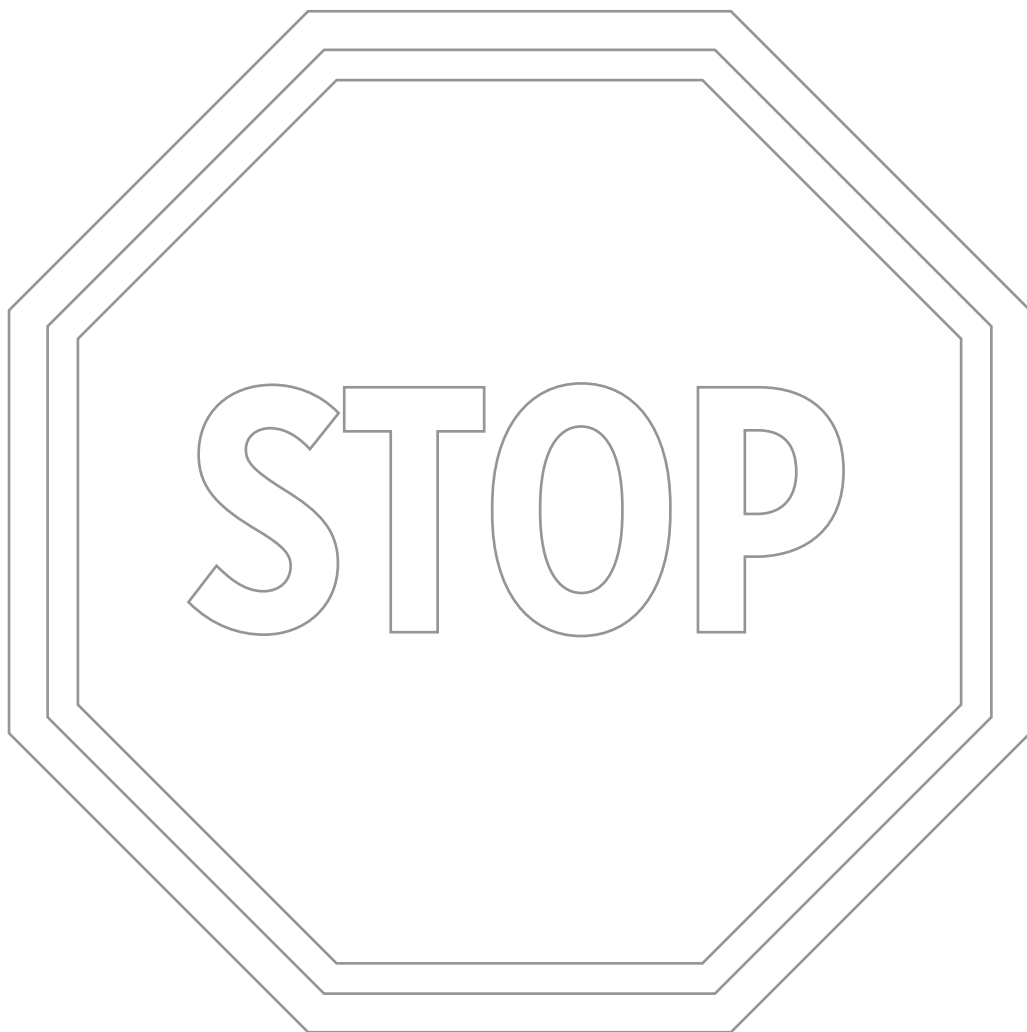

3

Match the number to the correct set. / Shetakanita nomora kulifano lyaghuhunga.

4



3

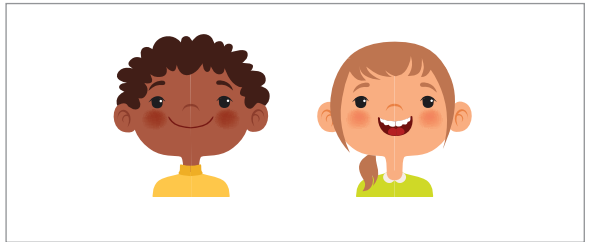

1

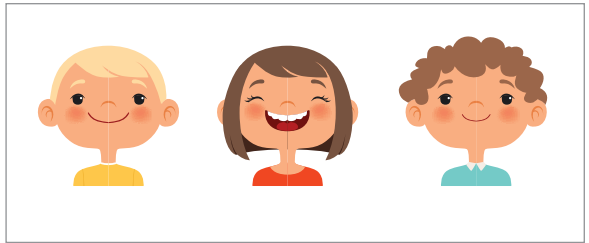

5

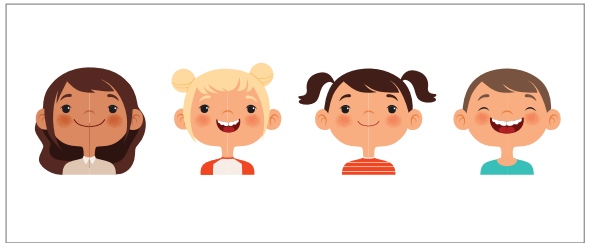

2

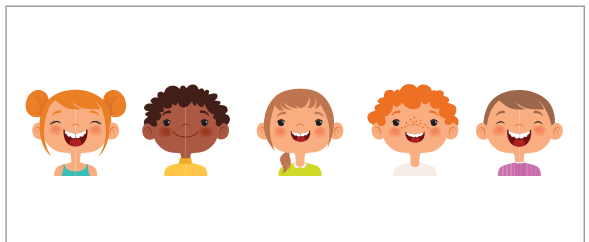

Shivike 18

Shure ntateko

Complete the following pattern: /Manita mapi ghana kukwamoko.

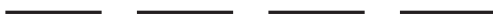
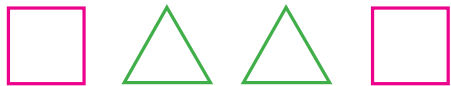

Shivike 18

Shure ntateko



Cut and paste the objects below on their matching number in the picture. / Tenga vikarata vyamafano kuntji nakuvirameka kunomora yina kushetakano nakehe nomora palifano.



Shivike 18

Shure ntateko





Trace the words and match the it to pictures. /
Dekera nkango nakudishetakanita kulifano lyaguhunga.



ruler /
shitaghulito

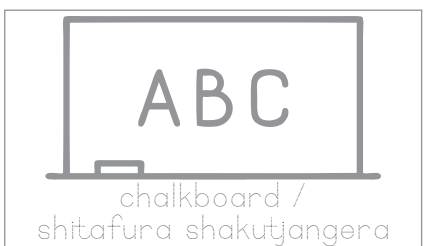

chalkboard /
shitafura
shakutjangerera

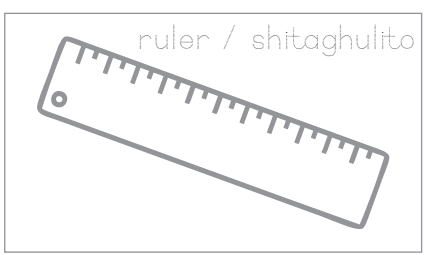

able /
ntishe

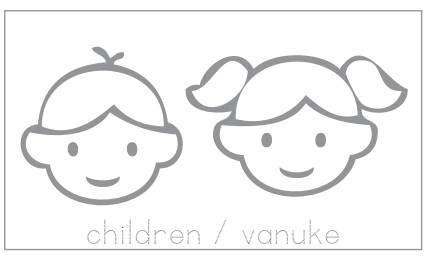

chair /
shipuna

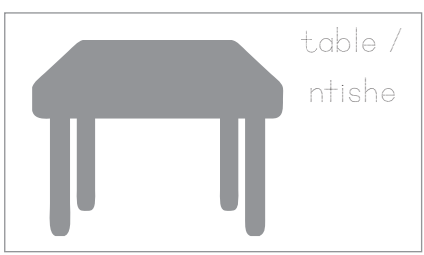

children /
vanuke

Shivike 18

Shure ntateko

Count the objects and write the correct number. /
Vara vininke nakutjanga nomora yaghuhunga mushimbangu.

Shivike 18

Shure ntateko

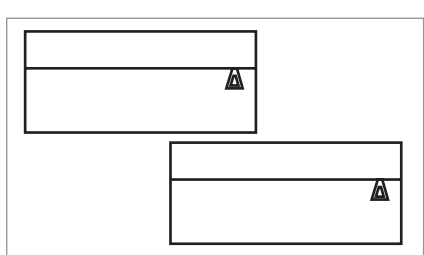
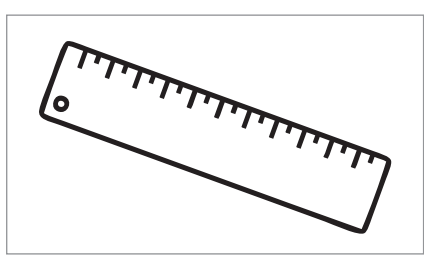
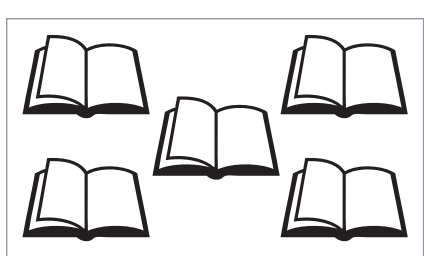
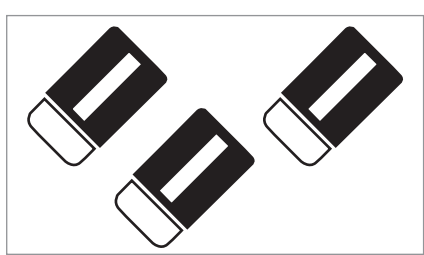
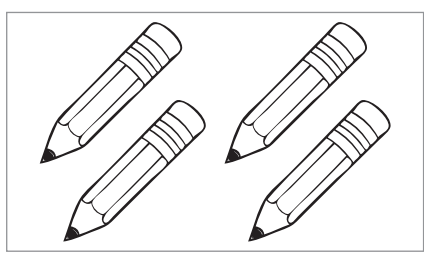

Success begins with education

Parents will be able to visit the website and watch daily videos or they can subscribe to our Zoshy Telegram channel to receive daily videos. One can also download the PDF version of the book on the website. Also watch our daily show on Active Kids to watch your favourite lessons.



<https://t.me/zoshyonline>



ONLINE

For extra perks!

How does it work?



Easy peasy steps to follow

Register at zoshy

You can save your favourite lessons and find them easier



- Step 1: Find us at www.zoshy.online or scan the QR code
- Step 2: Find your grade and select the year
- Step 3: Choose your language
- Step 4: Choose the week you want to learn out of
- Step 5: Choose lessons from what lessons there are
- Step 6: Download booklet if you do not have it
- Step 7: Watch and follow the teacher as she explains what to do in the book
- Step 8: Follow us on Facebook (Zoshy & Active Kids) to never miss a video
- Step 9: Subscribe to our Zoshy Telegram channel if you want to receive daily updates



www.zoshy.online

In collaboration with the Ministry of Education, Arts and Culture

PRINT

- 1** Turn the booklet to landscape.
- 2** Take a ruler & tear the booklet at the top long fold.
- 3** Fold the booklet in half.
- 4** The learning journey can start.

STEPS

HOW TO TEAR & USE THE BOOKLET



Weni omo ghuvura KURARA LIPENDA

popera vaghunyoye,
kupopere naghumoye



MAPENDA NAGHANTJE

KUDWATA

