

# Pre-primary: Week 17 & 18/ Ondondo yopetameko: oshiwike 17 no 18

5-6 years/ Oomvula 5-6

English / Oshindonga

Draw yourself in your school uniform. /  
Ithaneka mwene wa zala omuzalo gwosikola.

## My School / Osikola yandje



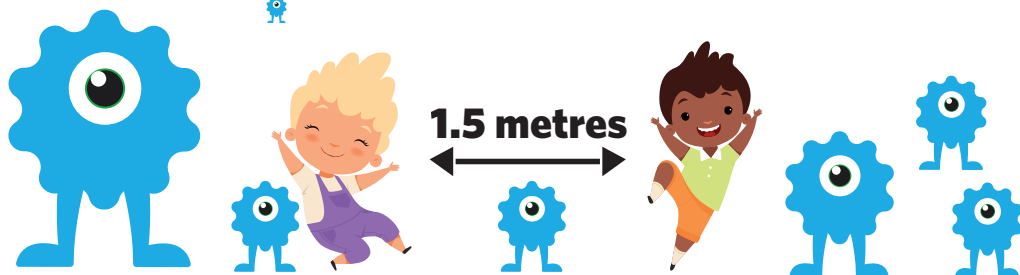

These numbers indicate which day you can complete each worksheet! But if you want to, you can work ahead and do the rest as well.

**This publication is a collaboration between the Ministry of Education, Arts and Culture and Namibia Media Holdings. This publication is sponsored by the Ministry.**

**Copyright © Ministry of Education, Arts and Culture.** All parts of this publication cannot be reproduced, stored in a retrieval system or transmitted in any form or by any means, electronic, mechanical, photocopying, recording or otherwise without prior permission of the Ministry of Education, Arts and Culture or the Publisher.

Production by: Namibia Media Holdings **NMH** NAMIBIA MEDIA HOLDINGS

Printing: Newsprint Namibia **newsprint** NAMIBIA

**The Ministry of Education, Arts and Culture**  
www.moe.gov.na



# My School / Osikola yandje

Identify names with same beginning sounds and circle them. /  
Totha mo omadhina ga tameka newindanda lyafaathana  
e to ga tula mongonga.



Titus



Anna



Tim



Tory

Mark with a cross (x) all the missing objects in the second picture. /  
Ninga okakombo kiinima ayihe ta yi holoka methano etiyali.

Oshiwike 17

Ondondo yopetameko





Cut out the pictures and paste them in the correct order. /  
Konda mo omathano e to ga nateke melandulathano.

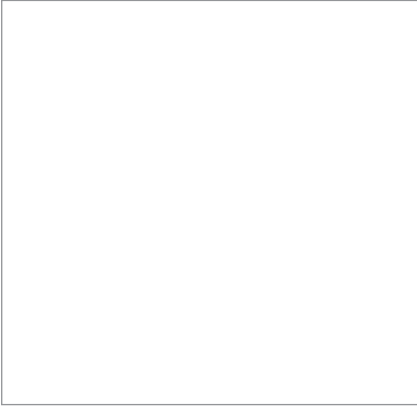

Oshiwike 17

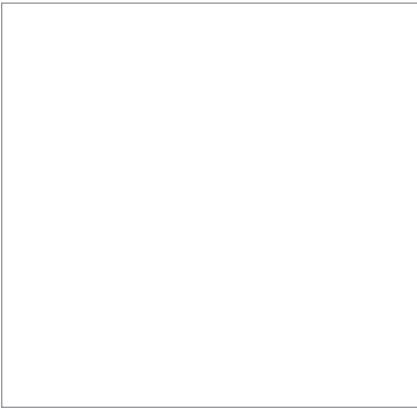

Ondondo yopetameko

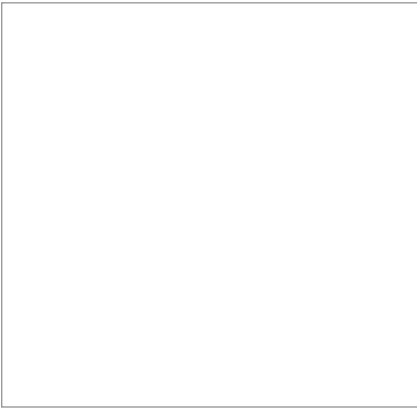



Trace the patterns. / Sindolola oompatolona.

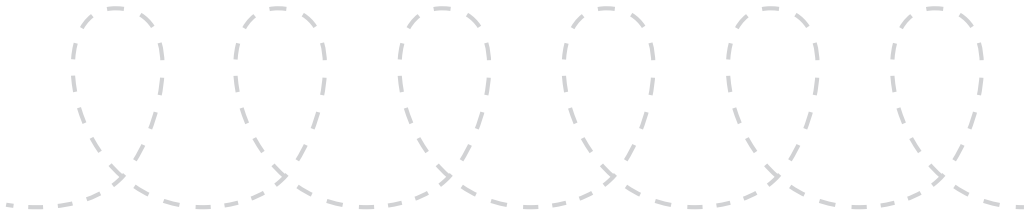

Oshiwike 17

Ondondo yopetameko

Draw a big circle. Then draw a small square in the circle. /  
Thaneka ongonga onene. Thaneka mo okambine mongonga.

Oshiwike 17

Ondondo yopetameko



Circle anything orange in the picture./  
Tula mongonga oshinima kehe oshitiliganeshunga methano.



Oshiwike 17

Ondondo yopetameko

Complete the number pattern. / Manitha ompatolonanomola.

5, 4, 3, 2, 1

Oshiwike 17

5, 4, \_\_, \_\_, \_\_

Ondondo yopetameko

1, 2, 3, 4, 3

\_\_\_ / \_\_\_ / \_\_\_ / \_\_\_ / \_\_\_

3, 2, 5, 2, 3

\_\_\_ / \_\_\_ / \_\_\_ / \_\_\_ / \_\_\_

Match the objects with the same length using lines. /  
Tsitha kumwe iinima yi na uule wu thike pamwe to longitha omusinda.

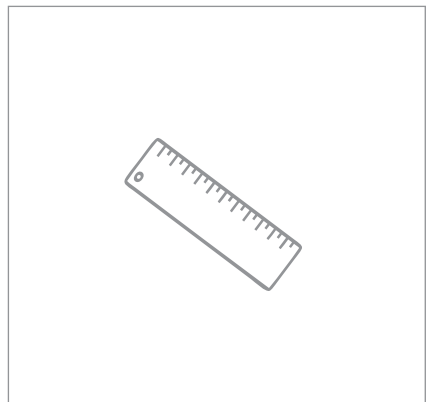
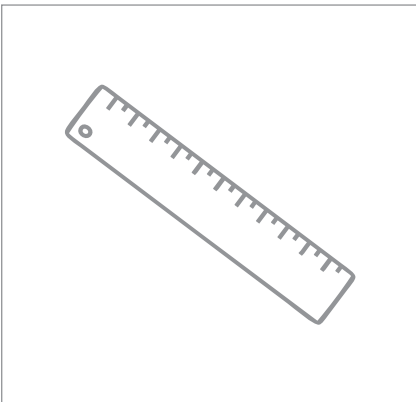
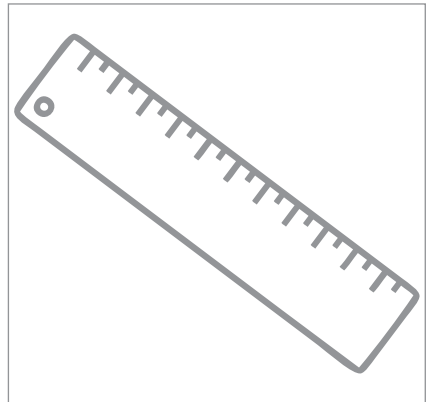
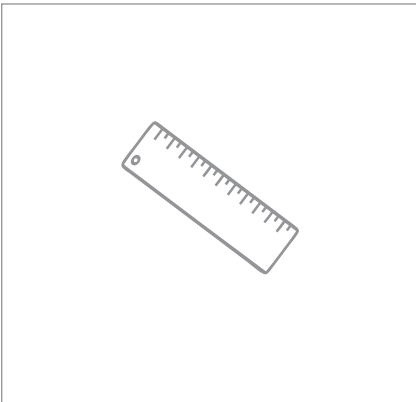
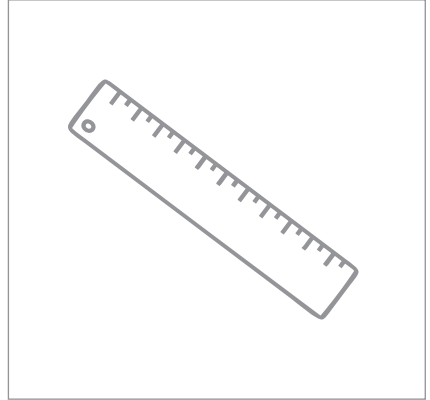
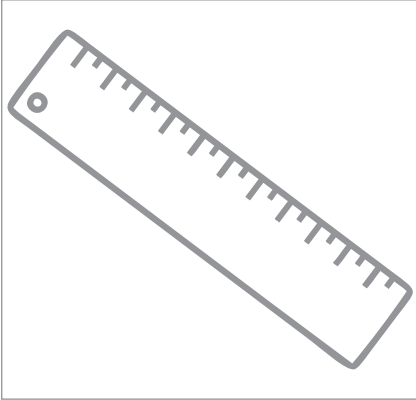

Spot the objects which are near and circle them. /  
Ndhindhilika iinima mbyoka yi li popepi e to yi tula mongonga.

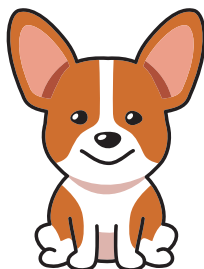
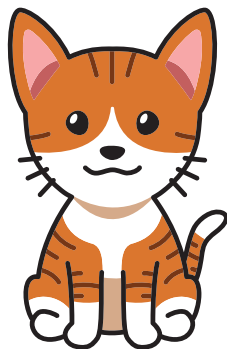



Cut out the glasses and paste them from full to empty. /  
 Konda mo omahalasa e to ga nateke okuza kwaandi  
 lyuudha sigo kwaandi lyaanasha.

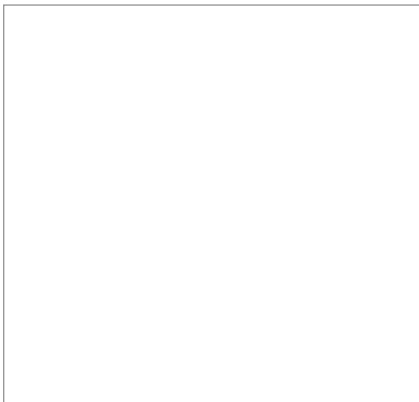
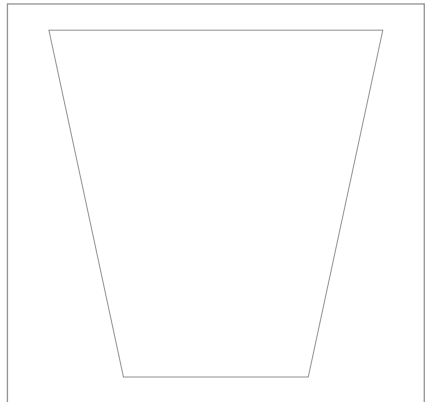
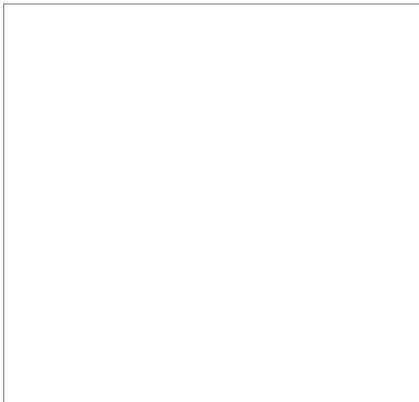
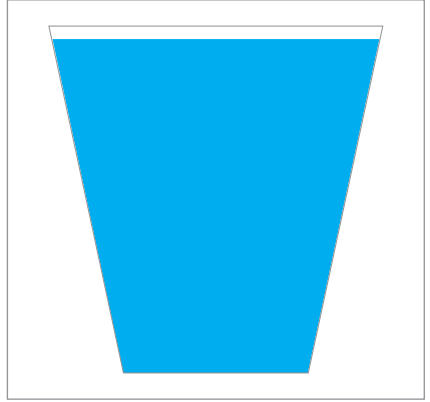
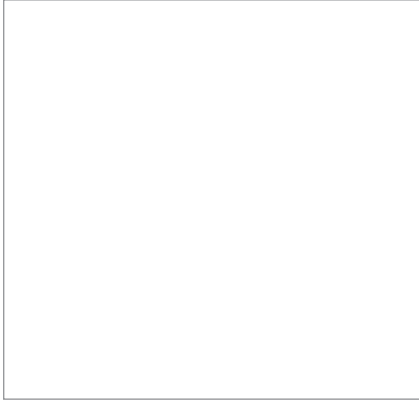



Circle all the number 5's. / Tula mongonga oo5 ayehe.

2 4 1 3 4

2 3 5 2 1

5 4 3 1 4

2 5 3 2

1 5 3 1 3

1 1 4 1

3 4 2 5

Oshiwike 17

Ondondo yopetameko

Trace the dotted triangle. / Sindolola muundothi wonkuvundatu.

Oshiwike 17

Ondondo yopetameko

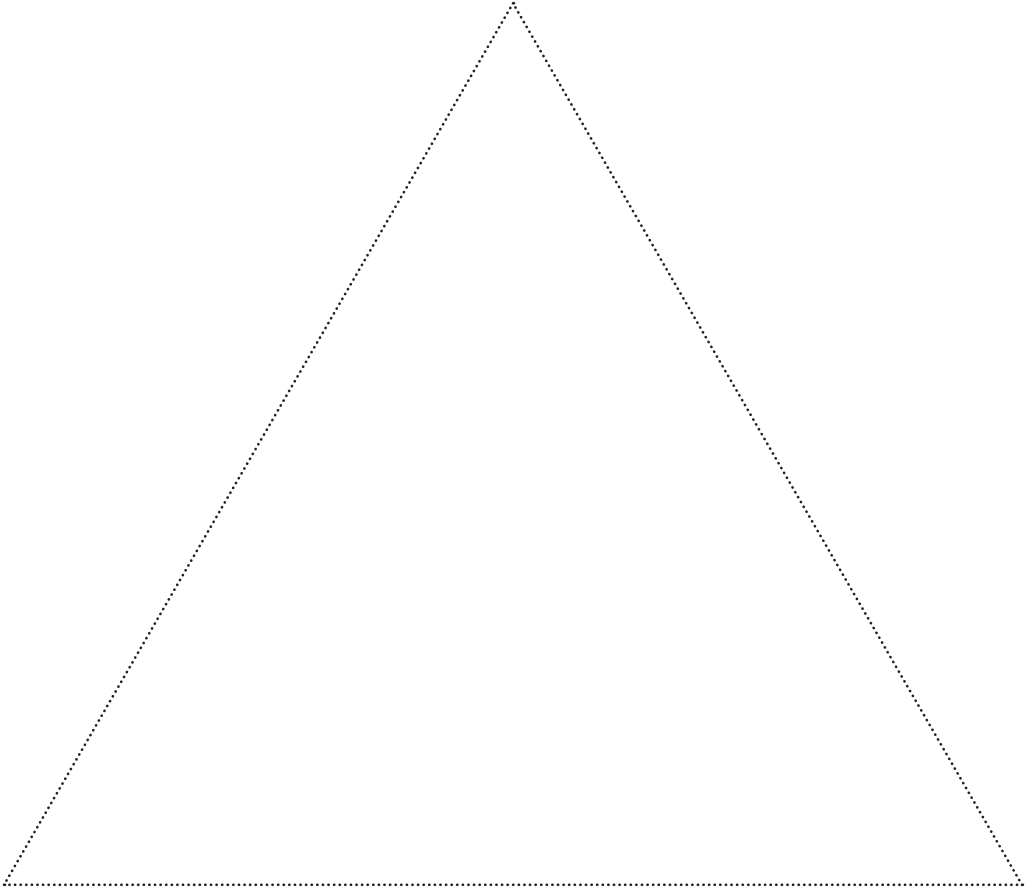

Draw a triangle. / Thaneka onkuvundatu.

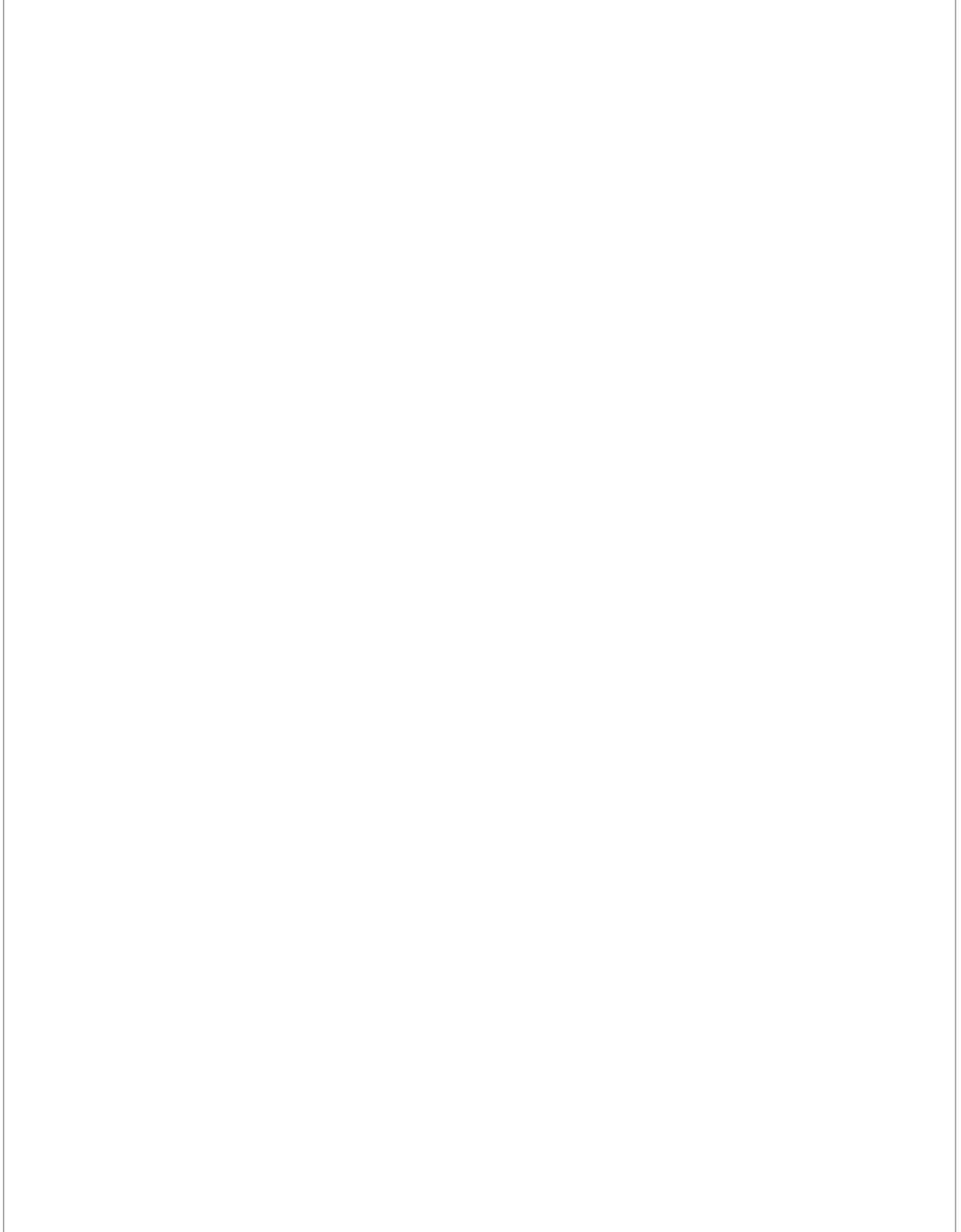

Colour all the triangles with an orange colour, all circles with a blue colour and all squares with yellow colour. / Mbapeka oonkuvundatu adhihe nolwaala olutiliganeshunga, oongonga adhihe nolwaala olumbulawu noombine adhihe nolwaala olushunga.

Oshiwike 18

Ondondo yopetameko

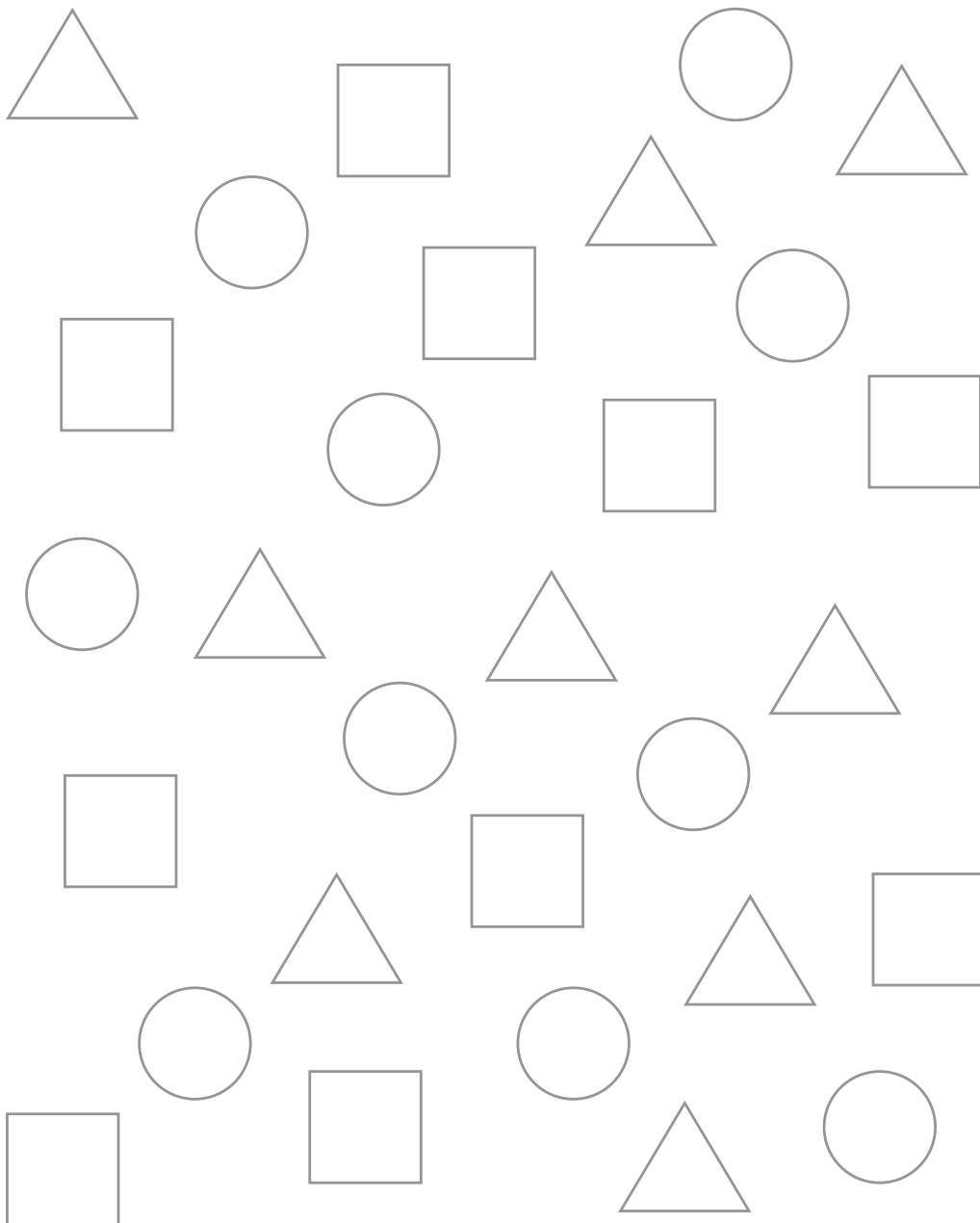

Mime what is shown in the picture. /  
Holela shoka tashi ulikwa methano.



Oshiwike 18

Ondondo yopetameko

Circle all clothes for cold weather. / Tula mongonga iizalomwa yonkaloyombepo ya talala.

Oshiwike 18

Ondondo yopetameko

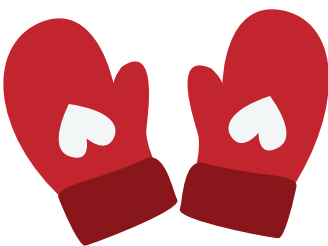
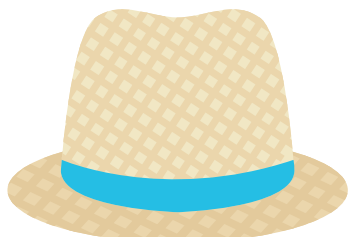
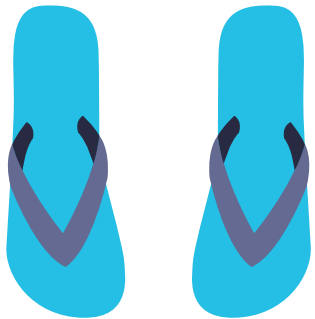
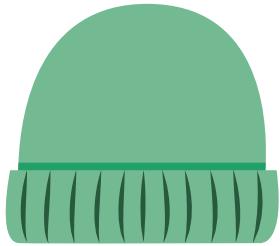



Identify with a cross (X) the correct picture when crossing the road. /  
Ulika nokakombo ethano lyomondjila ngele to taguluka ondjila.

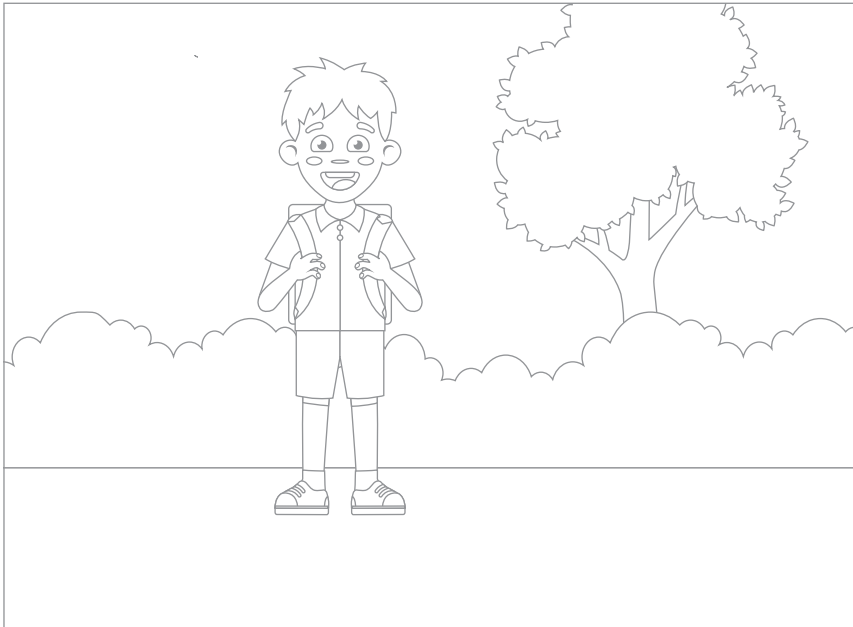
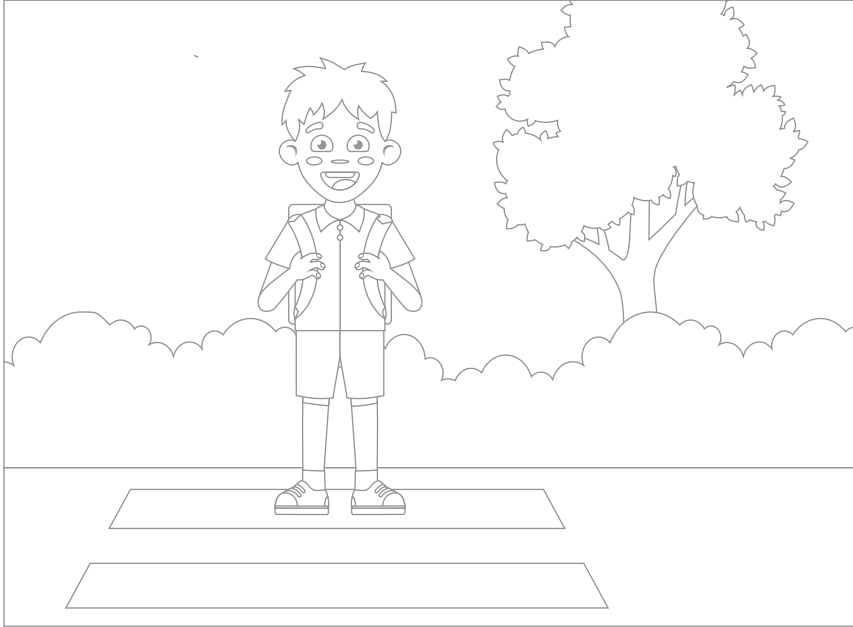

Circle all the 10c. / Tula mongonga oosenda 10 adhihe.



Oshiwike 18

Ondondo yopetameko



Draw any two classroom objects, talk about them with the teacher or parent./ Thaneka iilongitho kehe yomongulu yosikola e to popi kombinga yayo nomulongi/nomuvali gwoye.

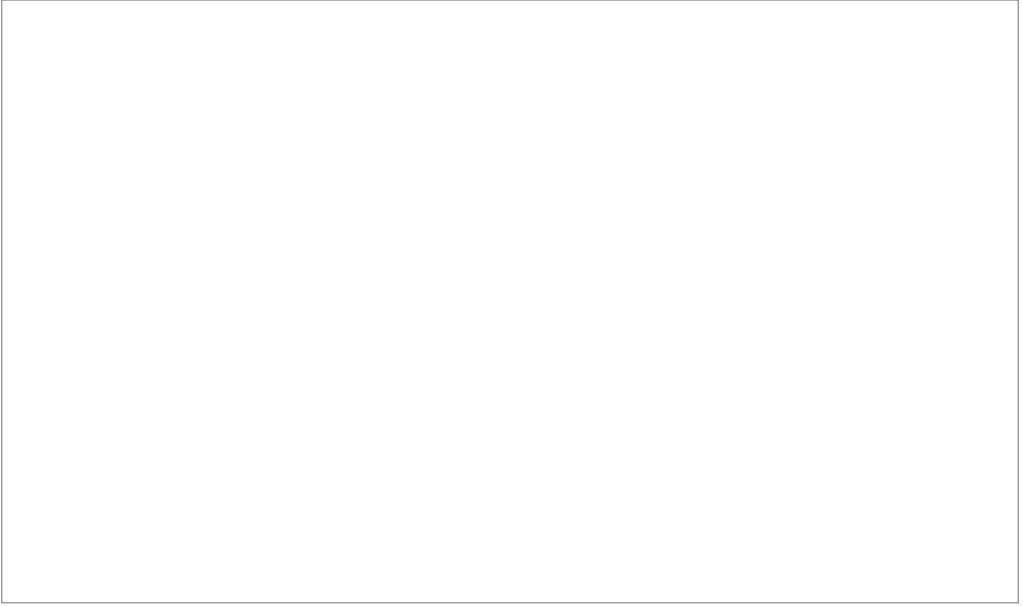

Colour the stop sign with a red crayon./  
Mbapeka ethano ndhindhiliko lyokuthikama nombapeka ontiligane.

Oshiwike 18

Ondondo yopetameko

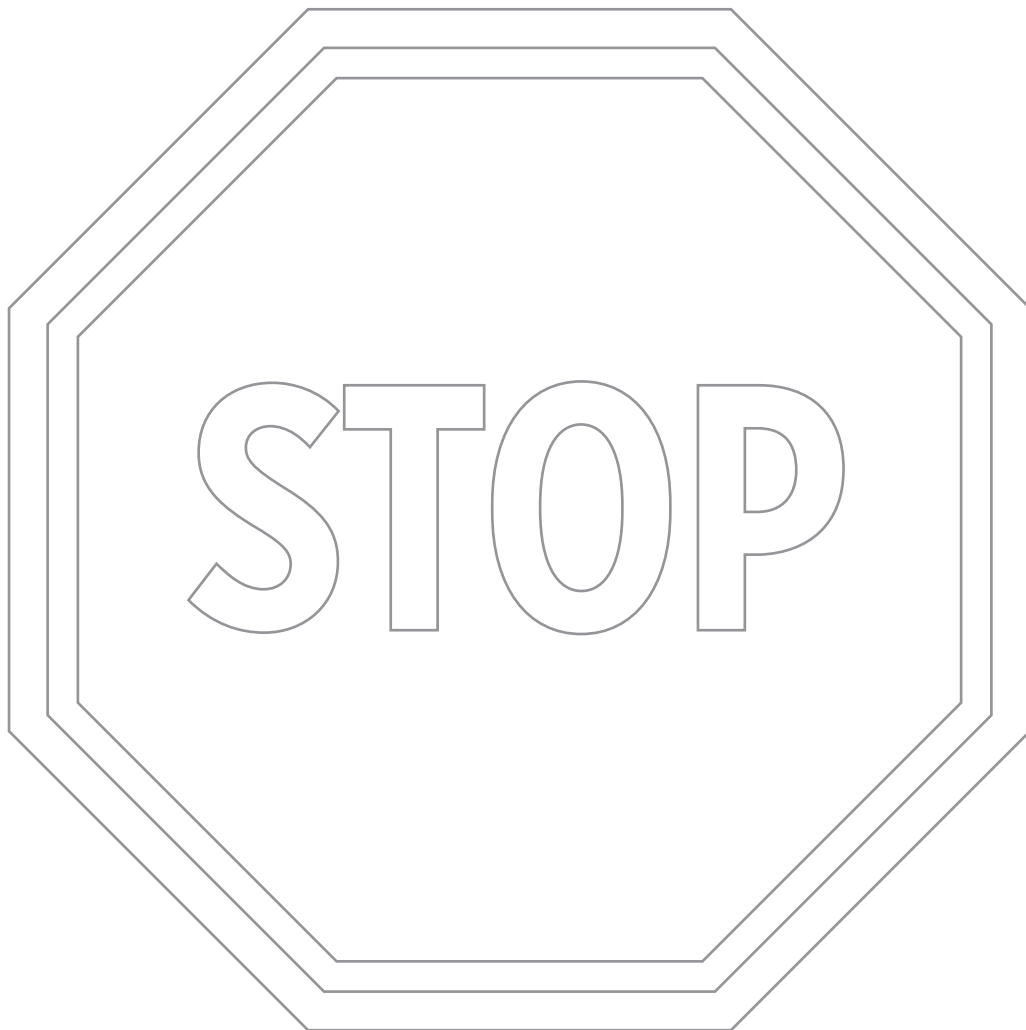

Match the number to the correct set. /  
Tsitha kumwe onomola nehwata lyomondjila.

4

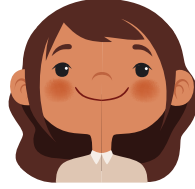

3

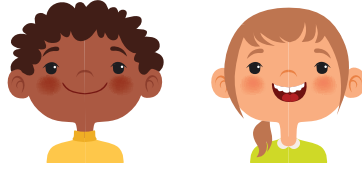

1



5



2



Complete the following pattern: /Manitha oompatolona tadhi landula:

Oshiwike 18

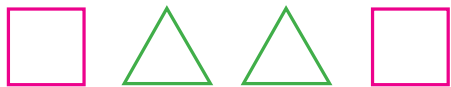

Ondondo yopetameko

Cut and paste the objects below on their matching number in the picture. / Konda e to nateke iinima yili pevi yitse kumwe nonomola yayo methano.



Oshiwike 18

Ondondo yopetameko







Trace the words and match the it to pictures.  
Sindolola iitya e to yi tsitha kumwe nomathano.

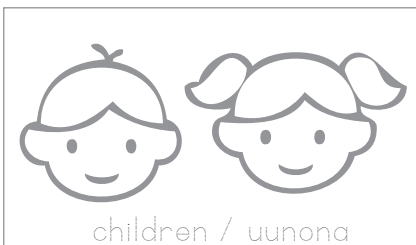
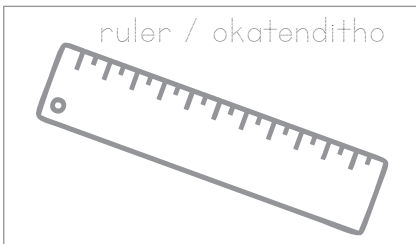
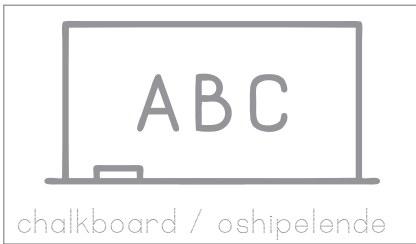

ruler /  
okatenditho

chalkboard /  
oshipelende

table /  
oshitaafula

chair /  
oshipundi

children /  
uunona

Count the objects and write the correct number. /  
Yalula iinima e to nyola onomola yomondjila.

Oshiwike 18

Ondondo yopetameko

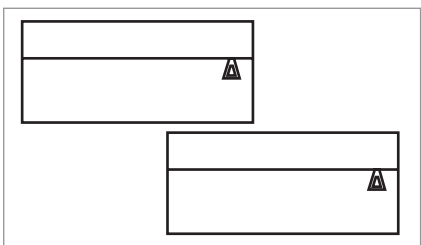
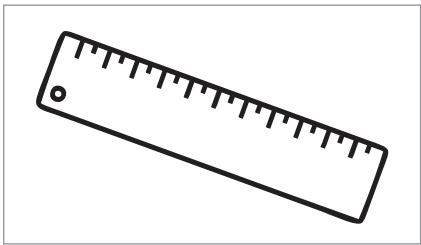
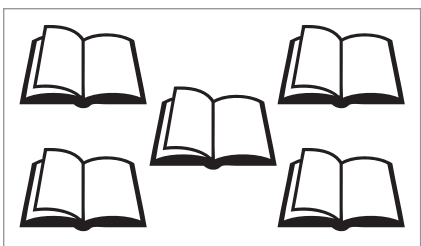
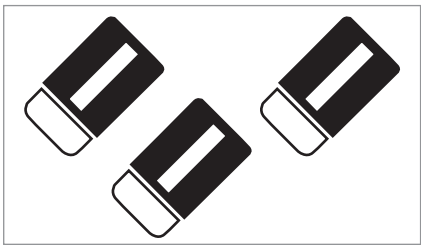
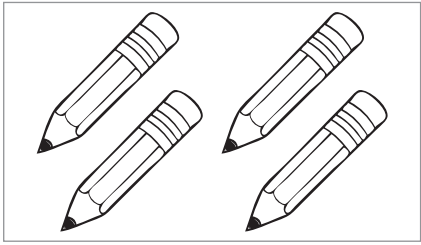

# Success begins with education

Parents will be able to visit the website and watch daily videos or they can subscribe to our Zoshy Telegram channel to receive daily videos. One can also download the PDF version of the book on the website. Also watch our daily show on Active Kids to watch your favourite lessons.



<https://t.me/zoshyonline>



**For extra perks!**

**How does it work?**

## Register at zoshy

You can save your favourite lessons and find them easier

## Easy peasy steps to follow

- Step 1: Find us at [www.zoshy.online](http://www.zoshy.online) or scan the QR code
- Step 2: Find your grade and select the year
- Step 3: Choose your language
- Step 4: Choose the week you want to learn out of
- Step 5: Choose lessons from what lessons there are
- Step 6: Download booklet if you do not have it
- Step 7: Watch and follow the teacher as she explains what to do in the book
- Step 8: Follow us on Facebook (Zoshy & Active Kids ) to never miss a video
- Step 9: Subscribe to our Zoshy Telegram channel if you want to receive daily updates

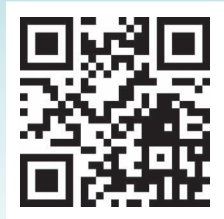

[www.zoshy.online](http://www.zoshy.online)

In collaboration with the Ministry of Education, Arts and Culture

**PRINT**

- 1** Turn the booklet to landscape.
- 2** Take a ruler & tear the booklet at the top long fold.
- 3** Fold the booklet in half.
- 4** The learning journey can start.

**STEPS**  
HOW TO TEAR & USE  
THE BOOKLET



# Nkene wuna okuninga EPEDAFULE

Gamena yakweni,  
ngoye wiigamene mwene



OMAPENDAFULE AGEHE OHA GA ZALA

**uulapi wasiikila okana nomayulu**

